

NOTES:

1. THIS DRAWING DESCRIBES THE FUELAB FUEL PUMP HANGER ASSEMBLY.
2. FEATURES INCLUDE:
 - HANGER
 - MOUNTING BRACKET
 - PLUMBED, READY FOR USE.
 - PUMP(S)
 -
 - FILTER(S)
3. FUEL COMPATIBILITY INCLUDES:
 - GASOLINE (PUMP OR RACE)
 - METHANOL
 - ETHANOL (INCLUDING E85)
4. UNIQUE SERIAL NUMBER ON TOP FLANGE DOES NOT CONTAIN DIRECT INFORMATION IN DETERMINING MODEL NUMBER. CONTACT FUELAB FOR DETERMINATION OF MODEL NUMBER BASED ON SERIAL NUMBER.
5. SEE TABLES BELOW FOR DETERMINATION OF DESIRED MODEL NUMBER.

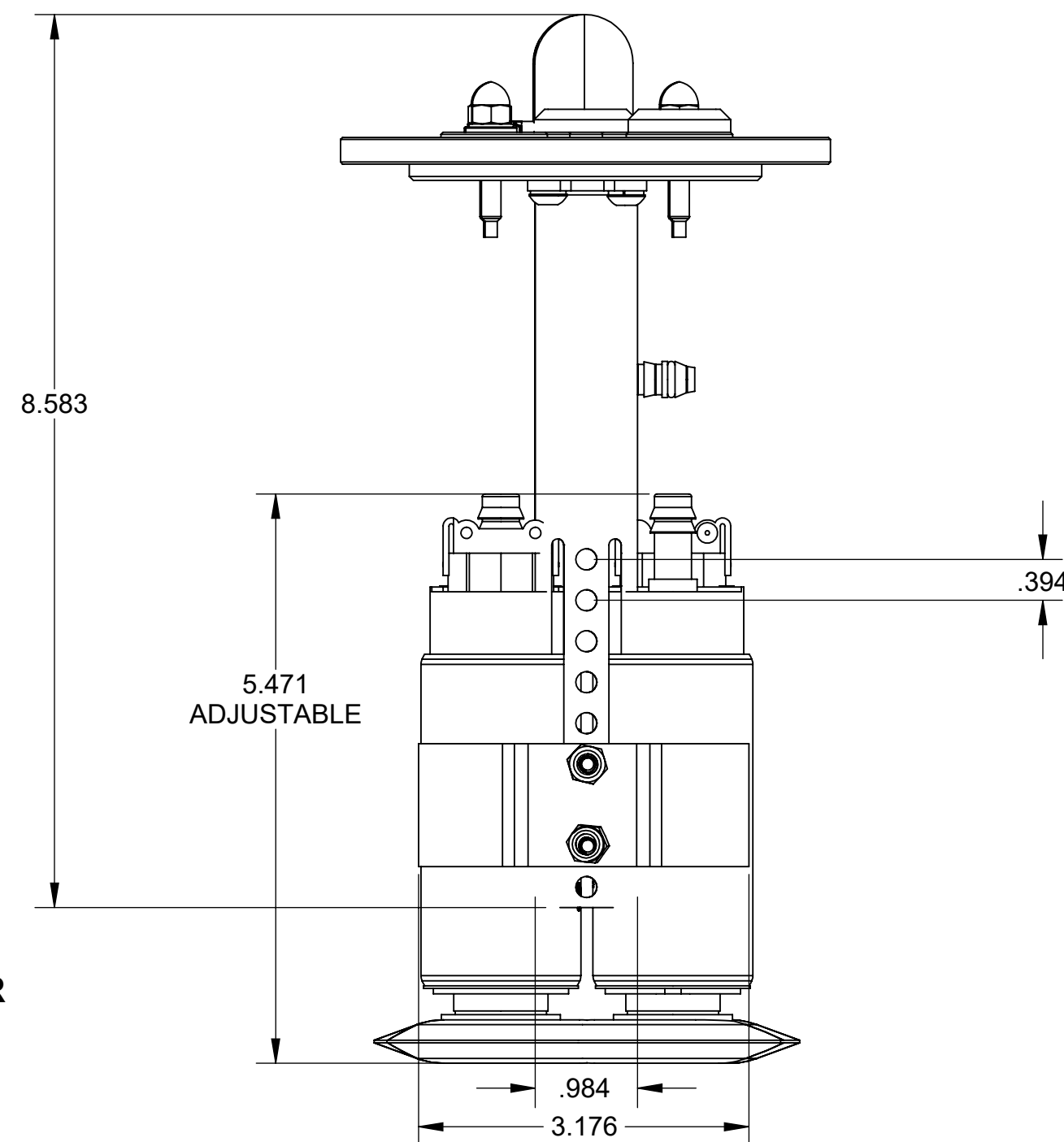

MODEL NUMBER SCHEME:

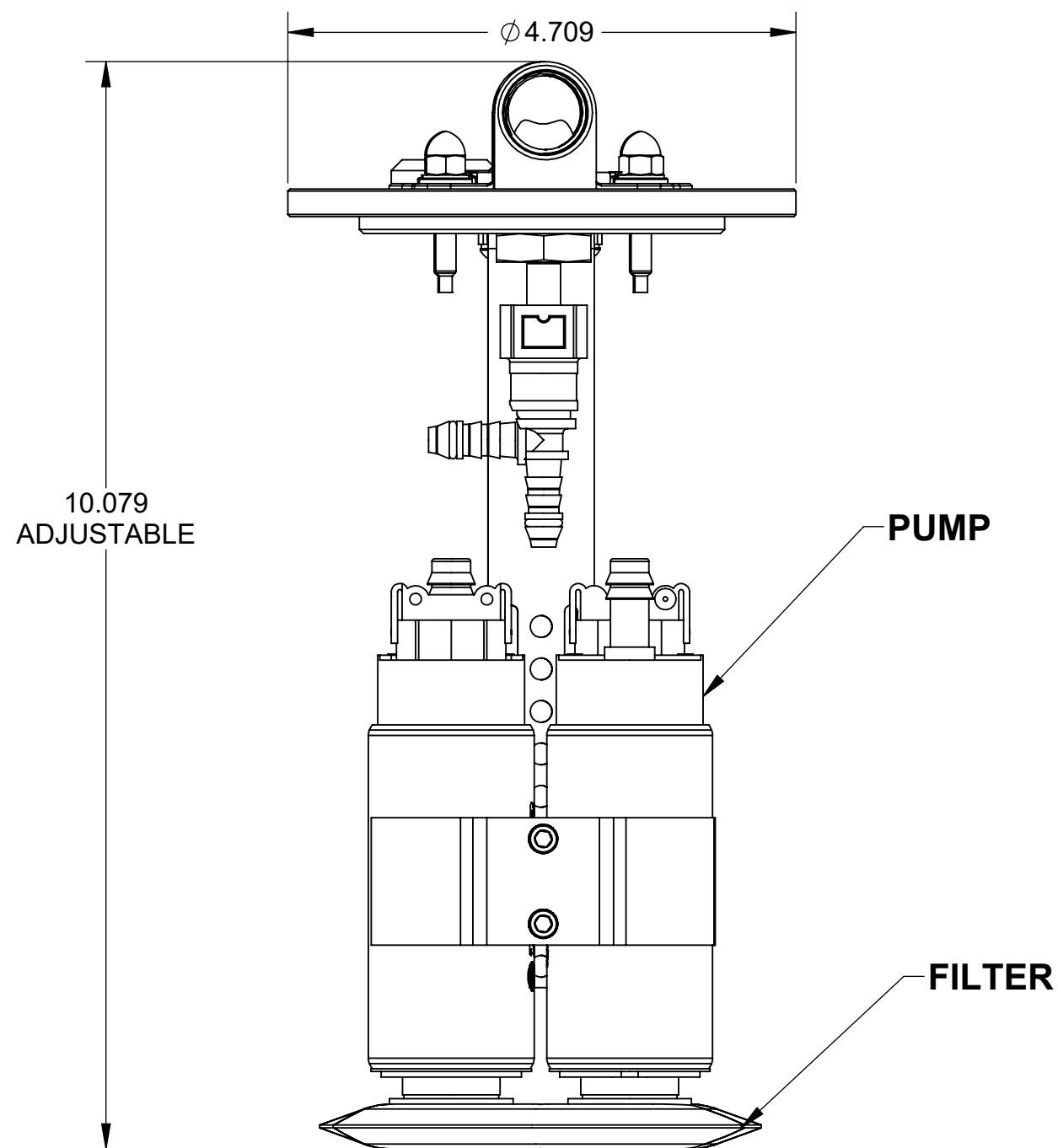
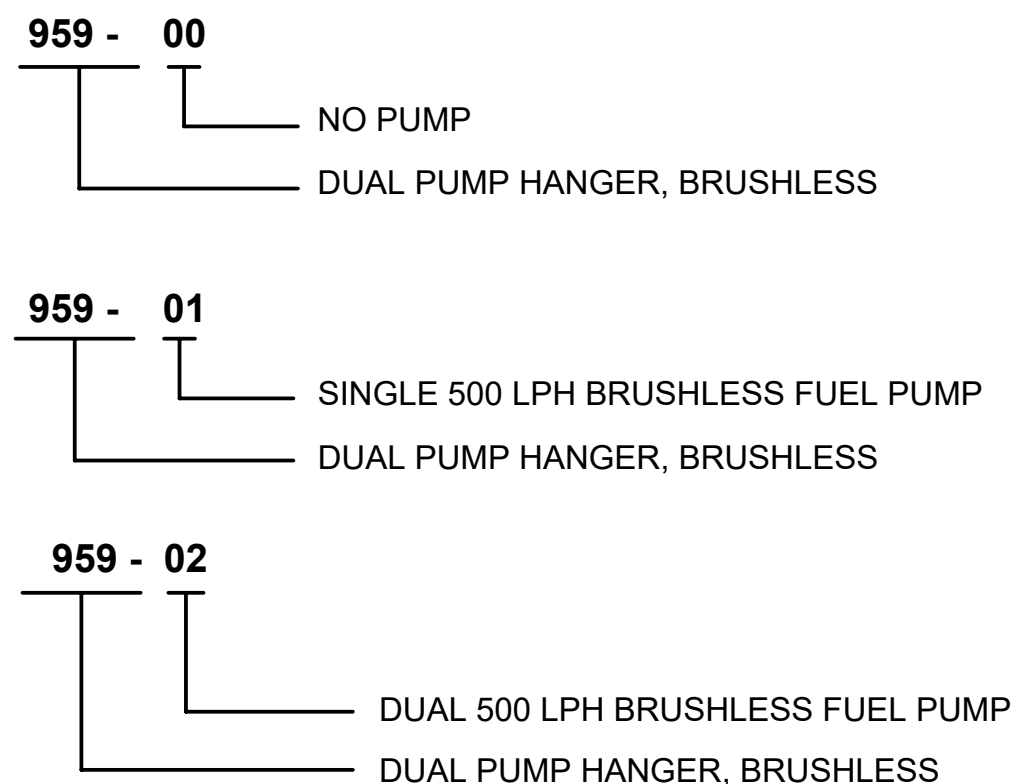

MODEL NUMBER SCHEME:

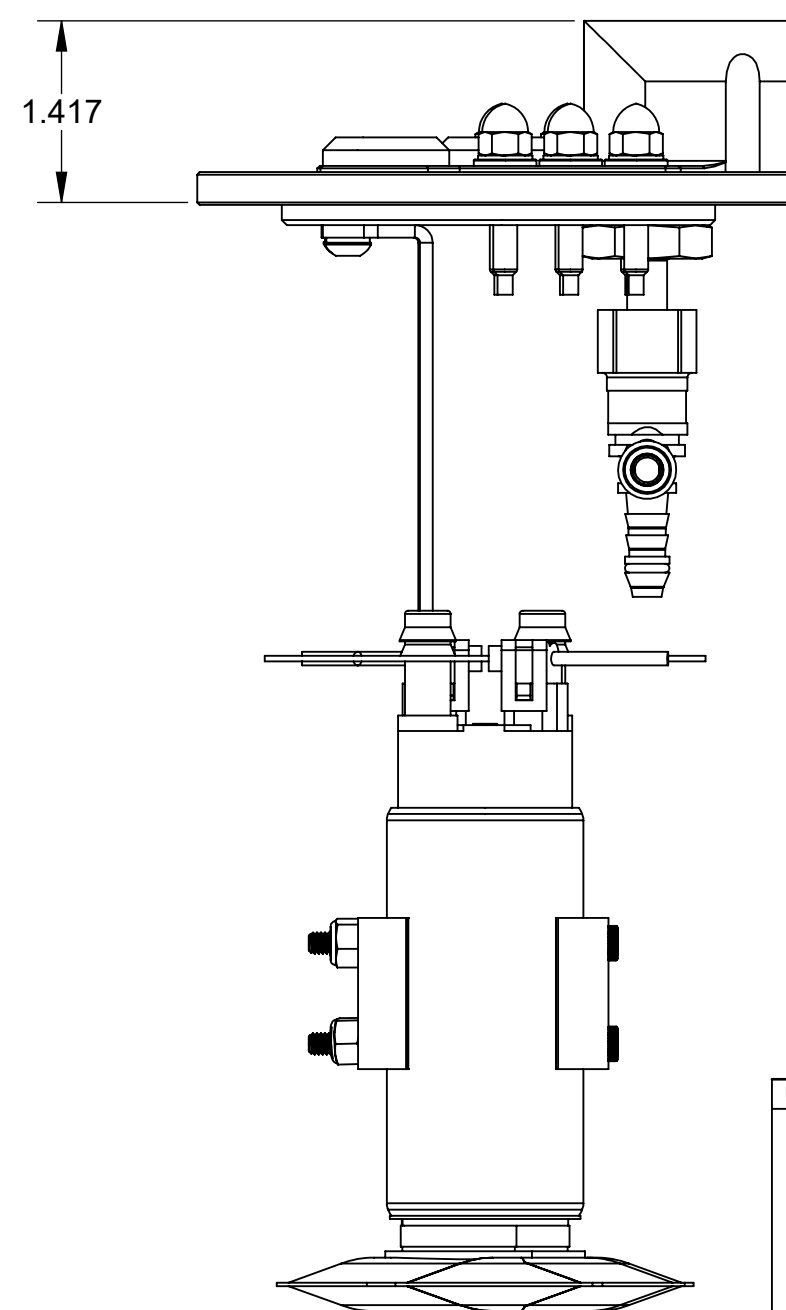
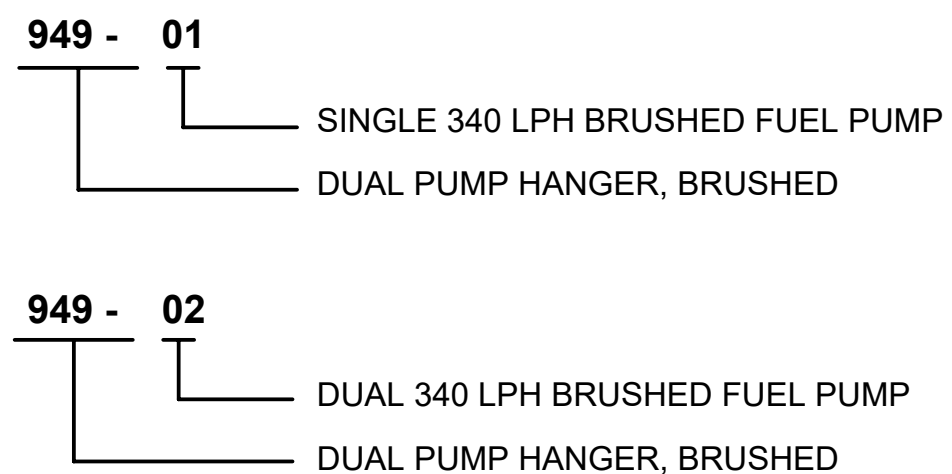

UNLESS OTHERWISE SPECIFIED:		FUELAB DIGITAL FUEL DELIVERY Collinsville, Illinois	
INTERPRET DWG PER ANSI Y14.5 DIMENSIONS ARE IN INCHES		TITLE: FUEL PUMP HANGER ASSEMBLY	
TOLERANCES: FRACTIONAL: ± 1/64" ANGULAR: ± 1/2° DECIMALS: X+.1 .XX±.03 .XXX±.010		SIZE C	DWG. NO. 155020900
SURFACE FINISH 128 ✓ OR BETTER		REV A	SCALE: 1/1
BREAK ALL SHARP EDGES .010 MAX REMOVE ALL BURRS		WEIGHT:	SHEET: 1 OF 1
THIRD ANGLE PROJECTION		DO NOT SCALE DRAWING	