

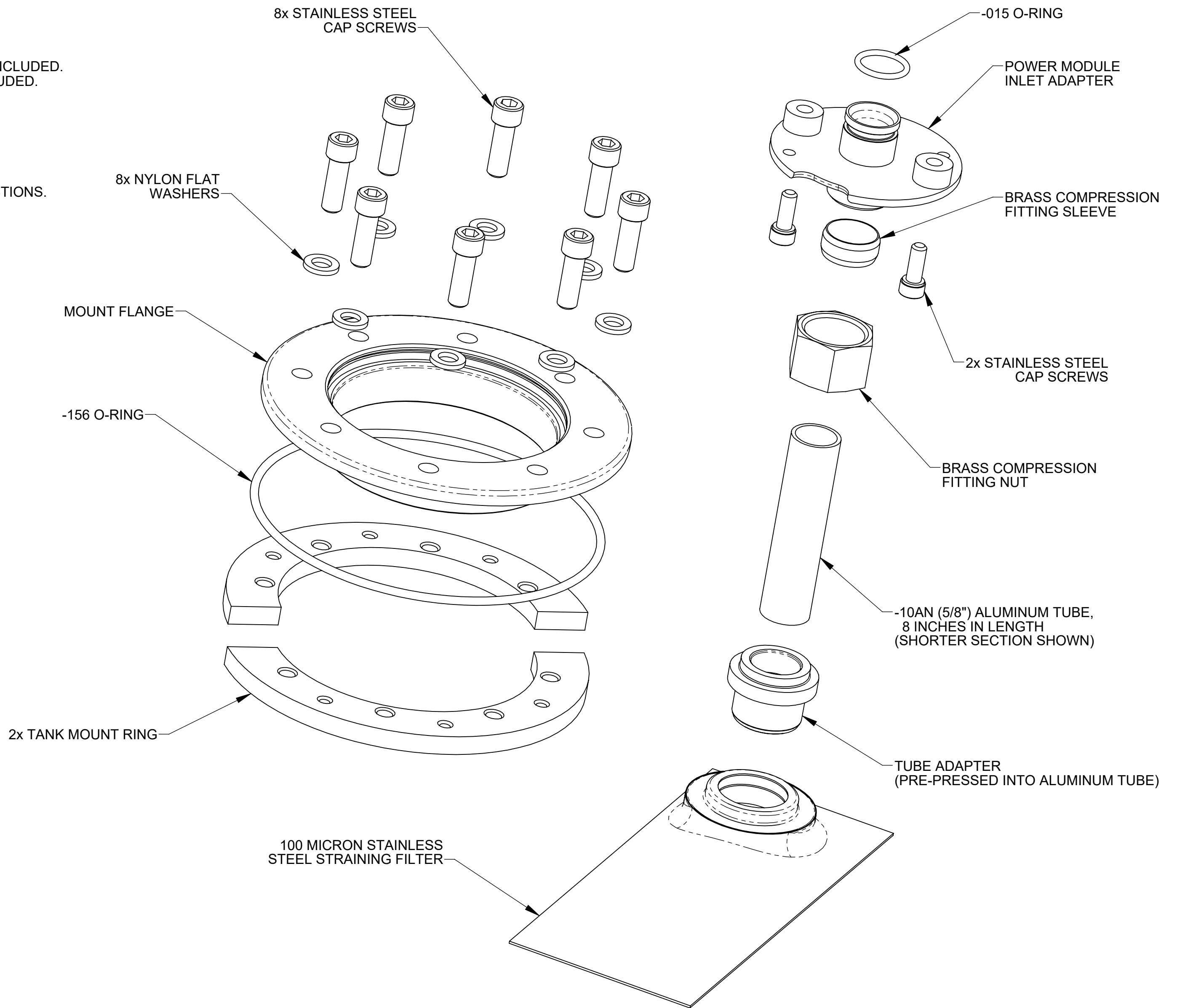

**NOTES:**

1. THIS DRAWING DESCRIBES THE FUELAB MODEL 20901 FABRICATOR INSTALLATION KIT.
2. FEATURES INCLUDE:
  - FOR USE WITH 90902, 91901, AND 92902 POWER MODULES (NOT INCLUDED).
  - METAL FABRICATION REQUIRED FOR INSTALLATION.
  - MOUNTING FLANGE, HARDWARE AND INLET PLUMBING INCLUDED.
  - STAINLESS STEEL 100 $\mu$  RELATIVE RATED ELEMENT INCLUDED.
3. FUEL COMPATIBILITY INCLUDES:
  - GASOLINE (PUMP OR RACE)
  - METHANOL
  - ETHANOL (INCLUDING E85)
  - DIESEL
4. REFERENCE DRAWING 1490201A1 FOR ASSEMBLY INSTRUCTIONS.

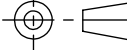

**CONTENTS OF INSTALLATION KIT SHOWN ABOVE**

UNLESS OTHERWISE SPECIFIED:		 COLLINSVILLE, ILLINOIS	
INTERPRET DWG PER ANSI Y14.5 DIMENSIONS ARE IN INCHES TOLERANCES: FRACTIONAL: $\pm 1/64"$ ANGULAR: $\pm 1/2^\circ$ DECIMALS: X+.1 .XX $\pm$ .03 .XXX $\pm$ .010 SURFACE FINISH $\sqrt{128}$ OR BETTER BREAK ALL SHARP EDGES .010 MAX REMOVE ALL BURRS		TITLE: <b>INSTALLATION KIT,                  MODEL 20901</b>	
SIZE <b>C</b>	DWG. NO. <b>149020100</b>	REV <b>C</b>	SCALE: 1/1 WEIGHT: .95 LB SHEET: 1 OF 2
THIRD ANGLE PROJECTION 		DO NOT SCALE DRAWING	

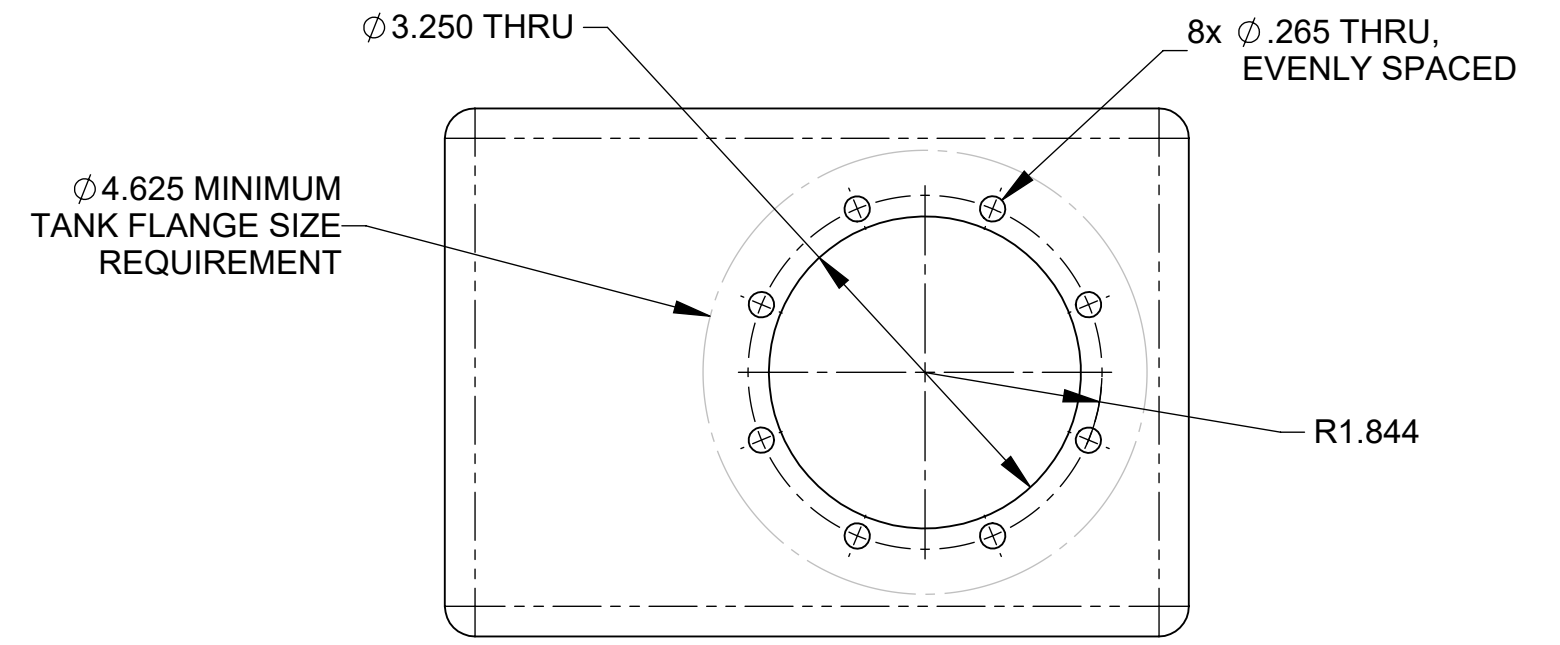
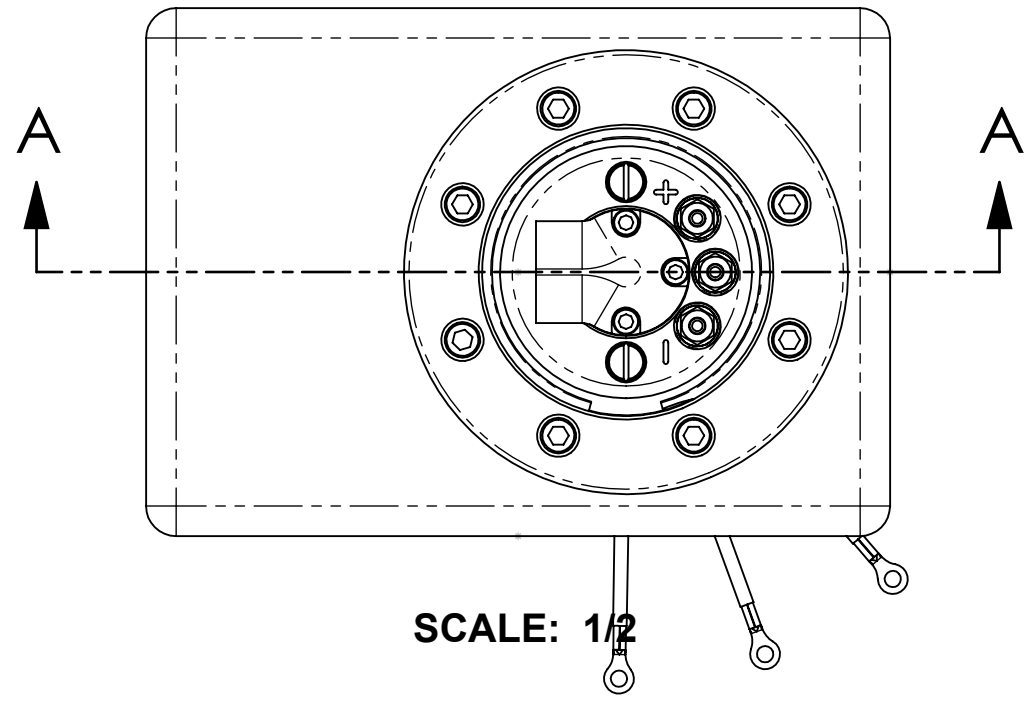

FUELAB POWER MODULE  
SHOWN INSTALLED.  
(SOLD SEPARATELY)

TANK FABRICATION REQUIREMENT  
SHOWN ABOVE  
SCALE: 1/2

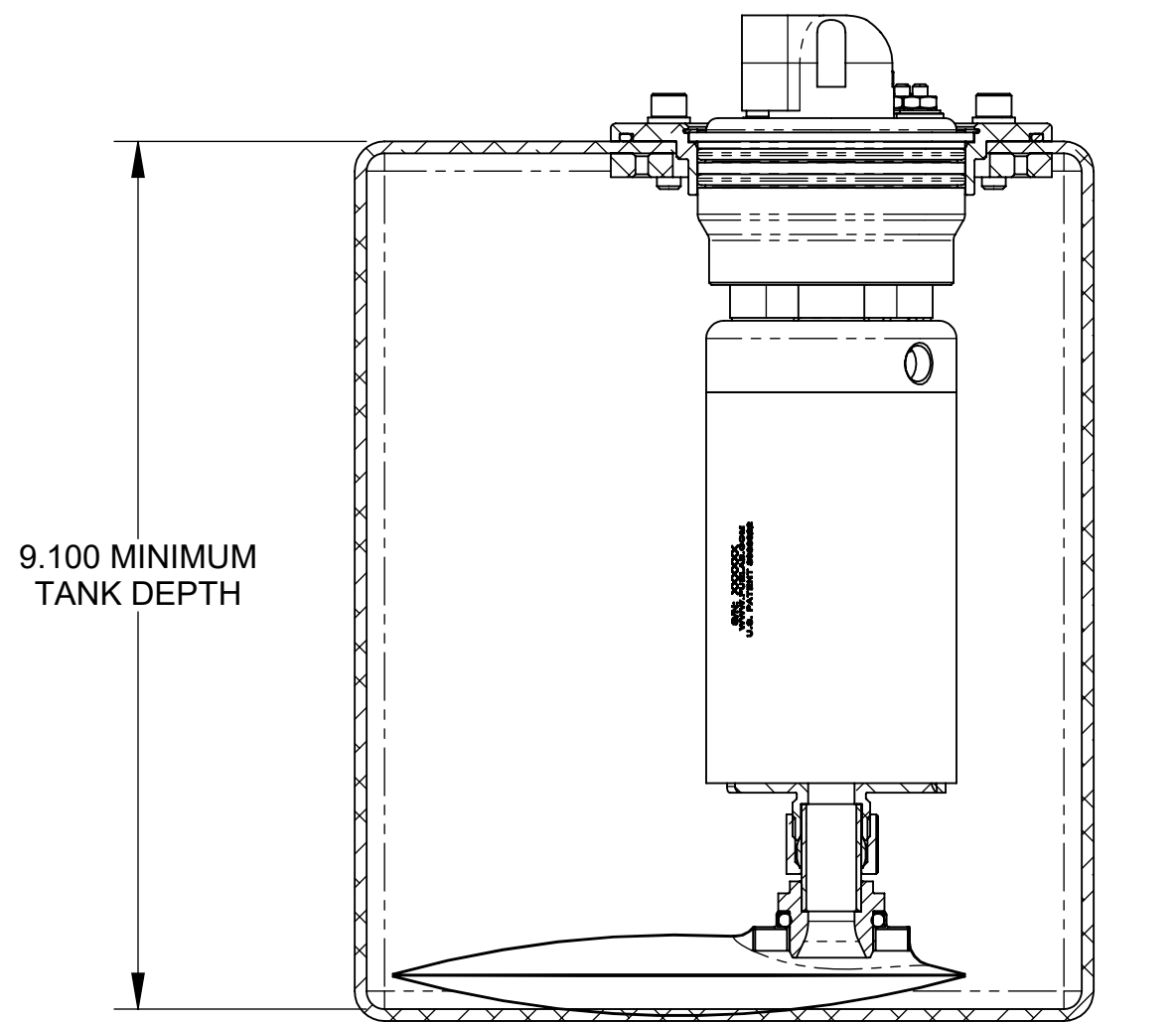

**SECTION A-A  
MINIMUM INSTALLATION HEIGHT  
WITH MODELS 90902, 91901 AND 92902  
SHOWN ABOVE  
SCALE: 1/2**

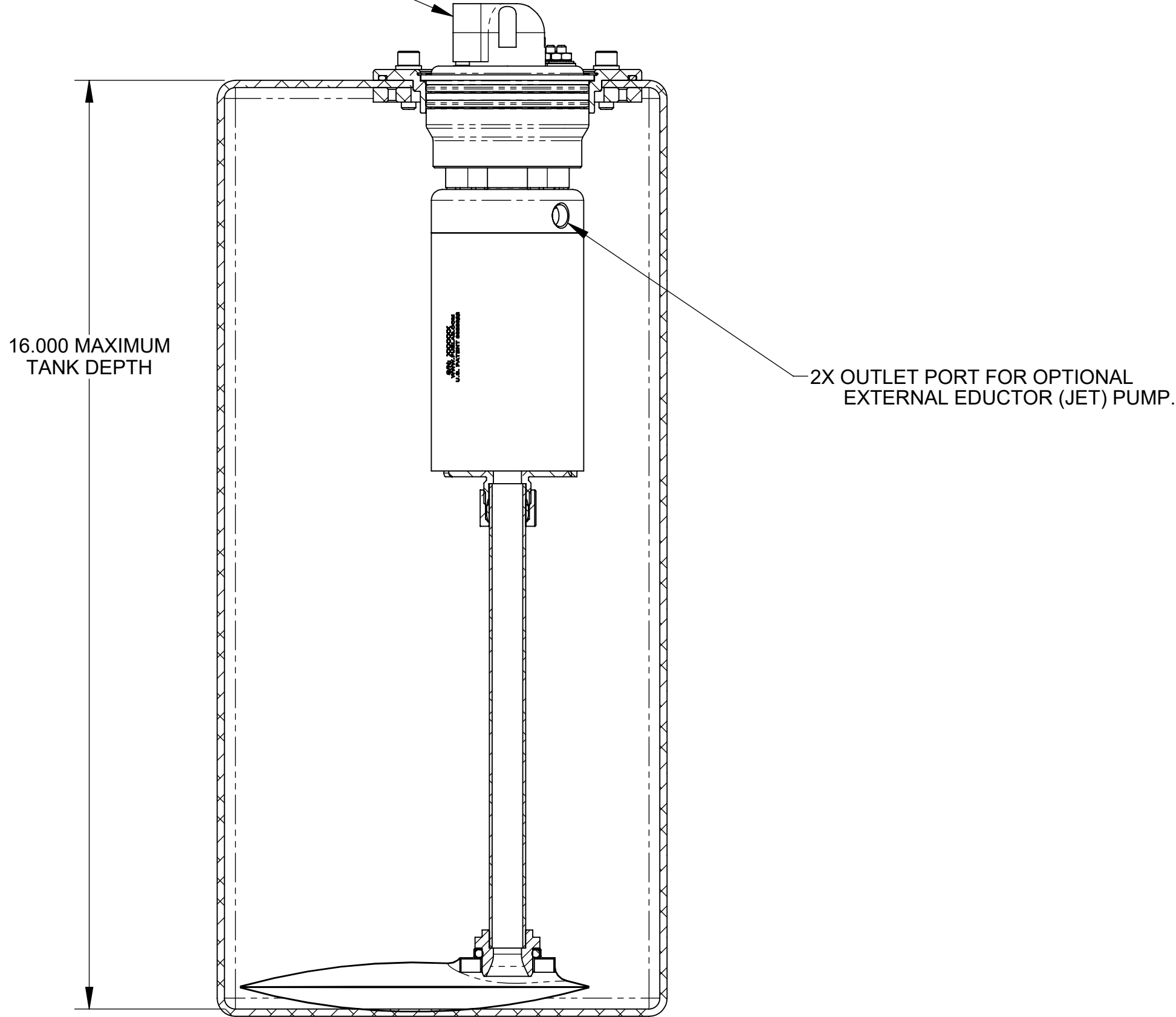

**SECTION A-A  
MAXIMUM INSTALLATION HEIGHT  
WITH MODELS 90902, 91901 AND 92902  
SHOWN ABOVE  
SCALE: 1/2**

UNLESS OTHERWISE SPECIFIED:		 <small>DIGITAL FUEL DELIVERY</small> Collinsville, Illinois	
<small>INTERPRET DWG PER ANSI Y14.5 DIMENSIONS ARE IN INCHES TOLERANCES: FRACTIONAL: ± 1/64" ANGULAR: ± 1/2° DECIMALS: X ± .1 .XX ± .03 .XXX ± .010 SURFACE FINISH 128 ✓ OR BETTER BREAK ALL SHARP EDGES .010 MAX REMOVE ALL BURRS</small>			
<small>THIRD ANGLE PROJECTION</small>		<small>TITLE:</small> <b>INSTALLATION KIT, MODEL 20901</b>	
<small>SIZE</small> <b>C</b>	<small>DWG. NO.</small> <b>149020100</b>	<small>REV</small> <b>C</b>	<small>SCALE: 1/1</small>
<small>DO NOT SCALE DRAWING</small>	<small>WEIGHT:</small>	<small>SHEET:</small> 2 OF 2	