

NOTES:

1. THIS DRAWING DESCRIBES THE FUELAB 405xx SERIES DC BRUSHLESS FUEL PUMP (SPUR GEAR).
2. FEATURES INCLUDE:
 - -12AN INLET AND -10AN OUTLET PORTS
 - THREE PHASE DC BRUSHLESS MOTOR WITH NEODYMIUM MAGNETS
 - WET MOTOR DESIGN, WITHOUT DYNAMIC SHAFT SEALS
 - SPUR GEAR STYLE PUMPING MECHANISM
 - INTEGRATED CONTROLLER ELECTRONICS WITH PWM SPEED CONTROL
 - BILLET ALUMINUM, STAINLESS STEEL CONSTRUCTION WITH FLUOROSILICONE SEALS
3. FUEL COMPATIBILITY INCLUDES:
 - GASOLINE (PUMP OR RACE)
 - METHANOL
 - ETHANOL (INCLUDING E85)
 - DIESEL
4. UNIQUE SERIAL NUMBER DOES NOT CONTAIN DIRECT INFORMATION IN DETERMINING MODEL NUMBER. CONTACT FUELAB FOR DETERMINATION OF MODEL NUMBER BASED ON SERIAL NUMBER.
5. PORT O-RINGS, MOUNTING BRACKETS, INSTRUCTIONS AND PERFORMANCE CERTIFICATION INCLUDED, BAGGED SEPARATELY FROM PUMP.
6. 8-24 VOLT OPERATING RANGE, USE BETWEEN 12 VOLT TO 24 VOLT (6 TO 12 CELL LEAD ACID BATTERY) VEHICLE SYSTEMS WITH OR WITHOUT CHARGING SYSTEM.
7. PUMP REQUIRES BYPASS REGULATOR OR RELIEF VALVE TO AVOID OVER-PRESSURE OPERATING CONDITION.
8. SEE TABLE BELOW FOR DETERMINATION OF DESIRED MODEL NUMBER.
9. REFERENCE DRAWING 1100210A1 FOR ASSEMBLY INSTRUCTIONS.

MODEL SELECTION TABLE

MODEL	FLOW RATING, AT 13.5v	FLOW RATING, AT 13.5v	MAX. PRESSURE
40501	5.5 GPM AT 45 PSI	1250 LPH AT 3.0 BAR	100 PSI (6.9 BAR)

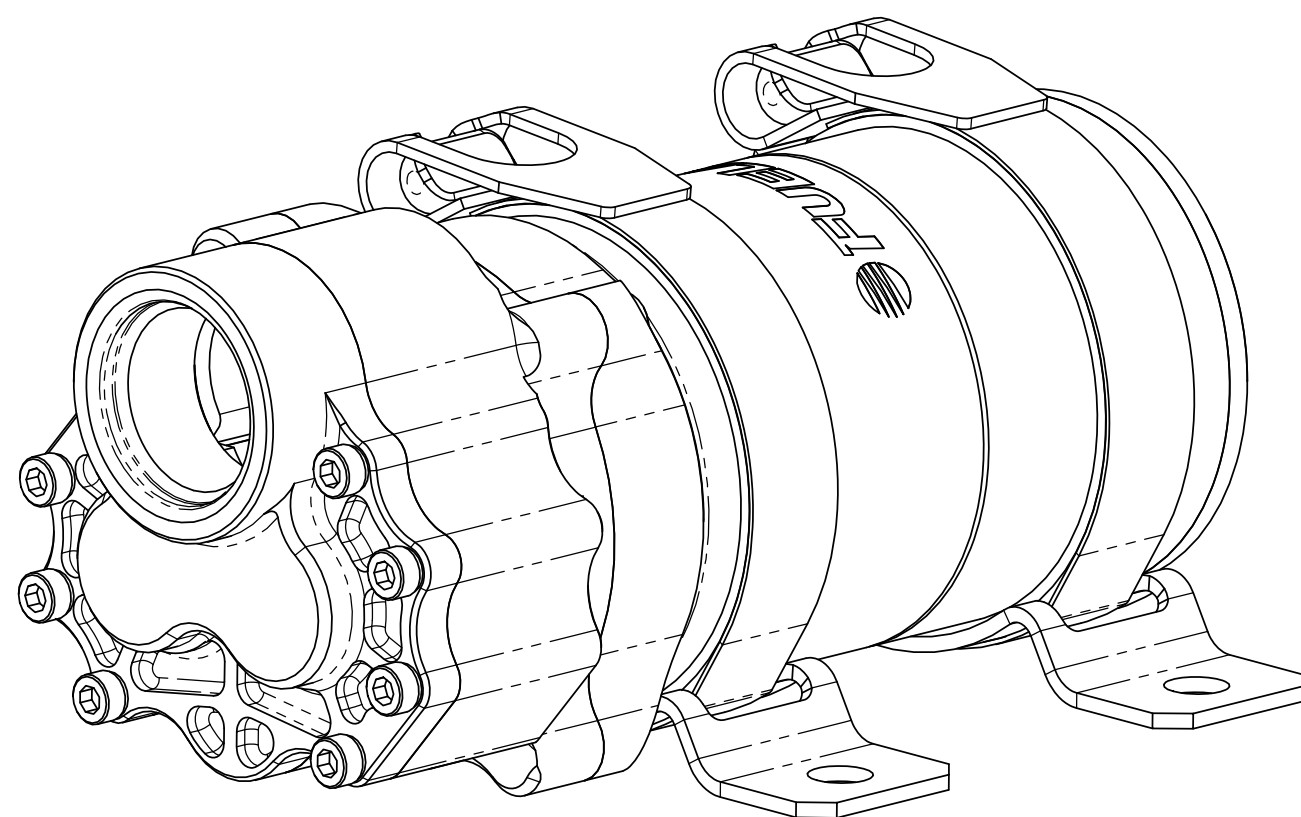

ISOMETRIC VIEW

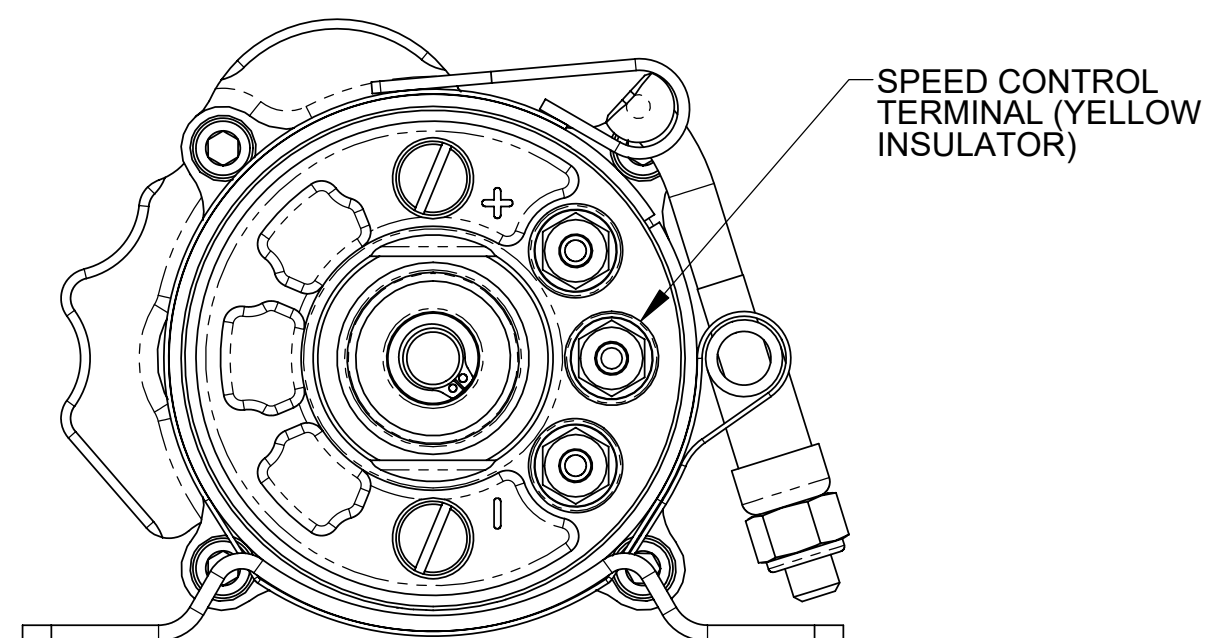
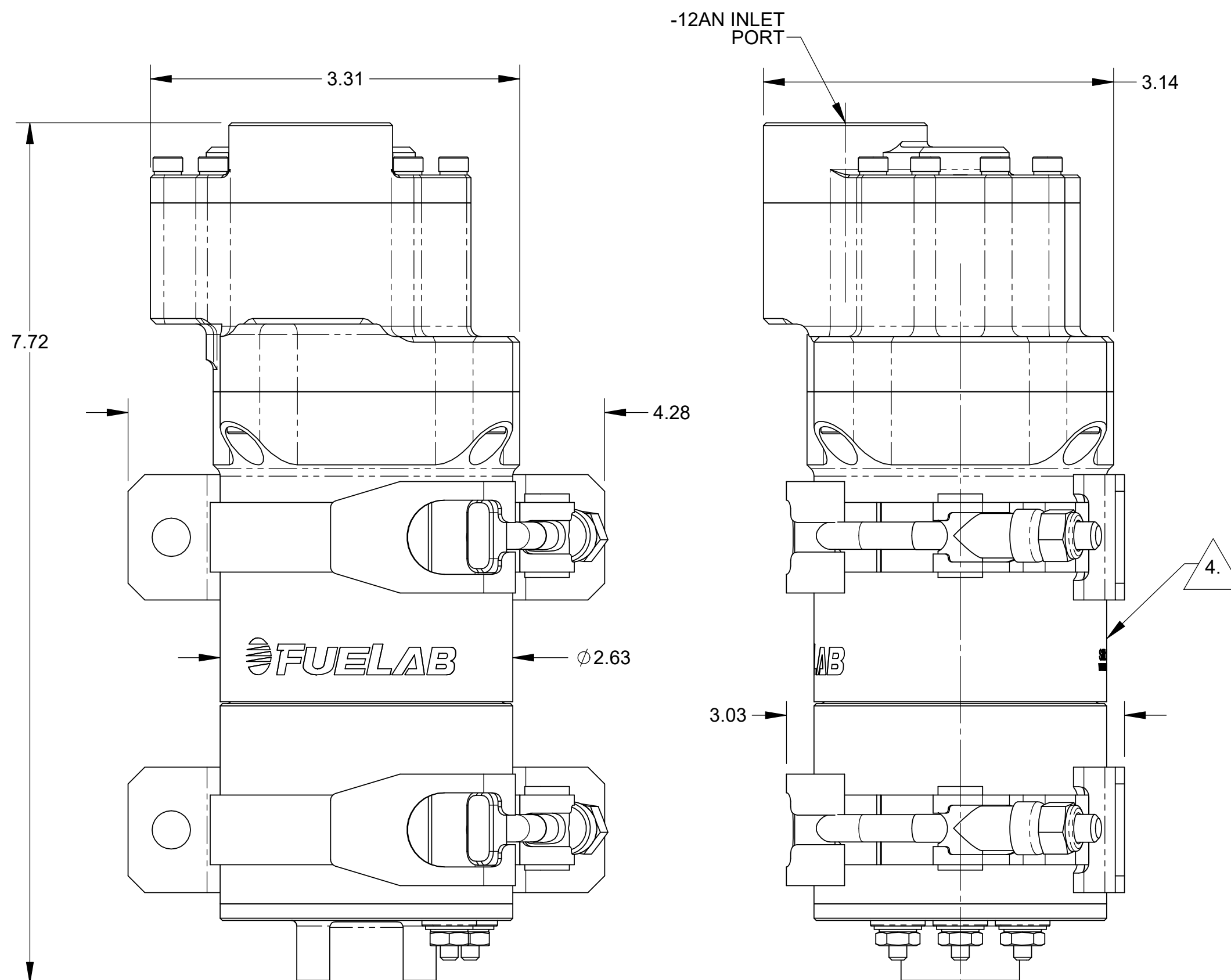

SPEED CONTROL TERMINAL (YELLOW INSULATOR)

UNLESS OTHERWISE SPECIFIED: INTERPRET DWG PER ANSI Y14.5 DIMENSIONS ARE IN INCHES TOLERANCES: FRACTIONAL: ±1/64" ANGULAR: ±1/2° DECIMALS: X±1 .XX±.03 .XXX±.010 SURFACE FINISH: 128 ✓ OR BETTER BREAK ALL SHARP EDGES .010 MAX REMOVE ALL BURRS		 COLLINSVILLE, ILLINOIS	
TITLE: DC BRUSHLESS FUEL PUMP, 405xx SERIES			
SIZE	DWG. NO.	REV	
C	110021000	A	
SCALE: 1/1		WEIGHT: 3.5 LBS	SHEET: 1 OF 2

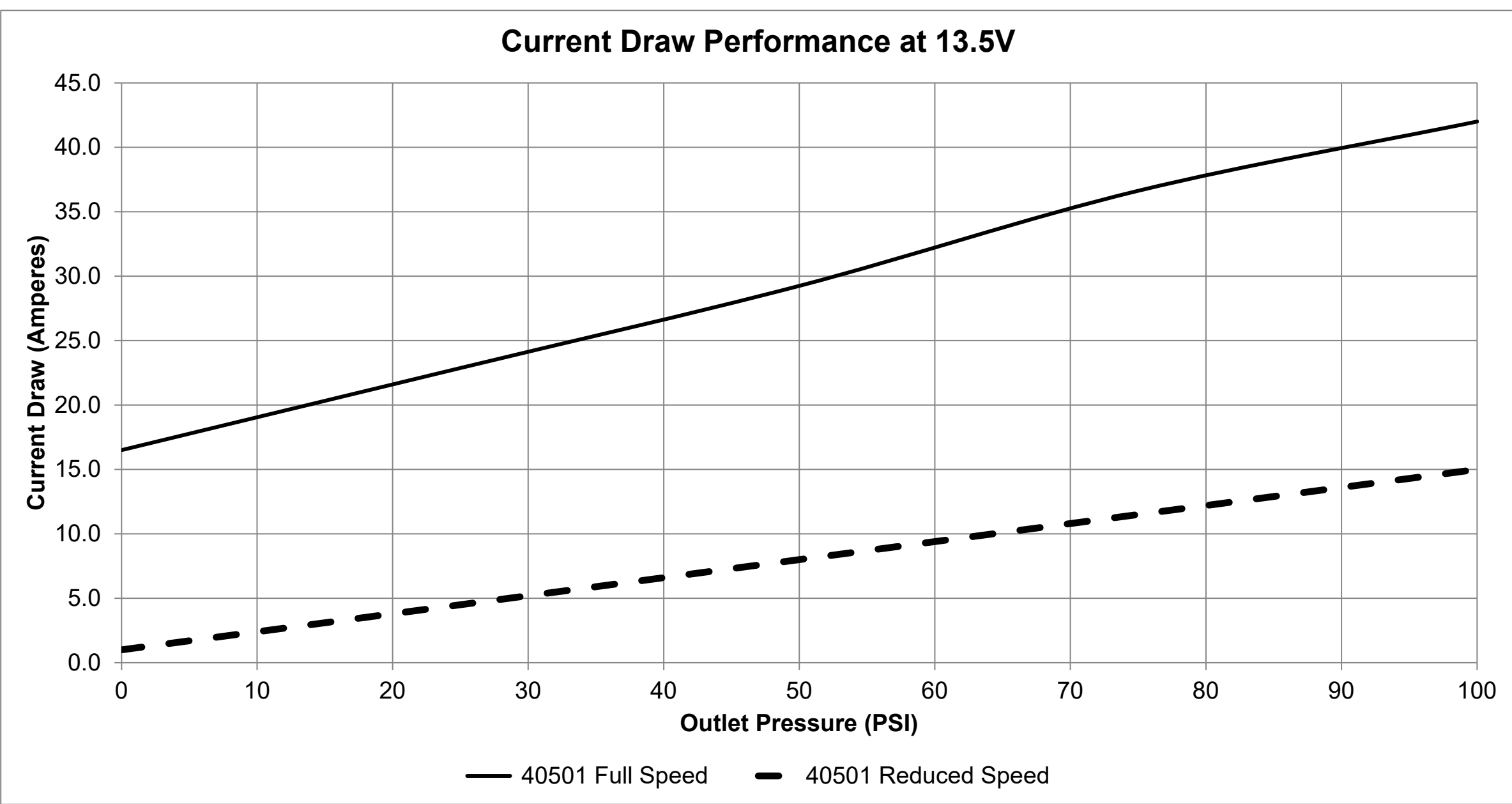
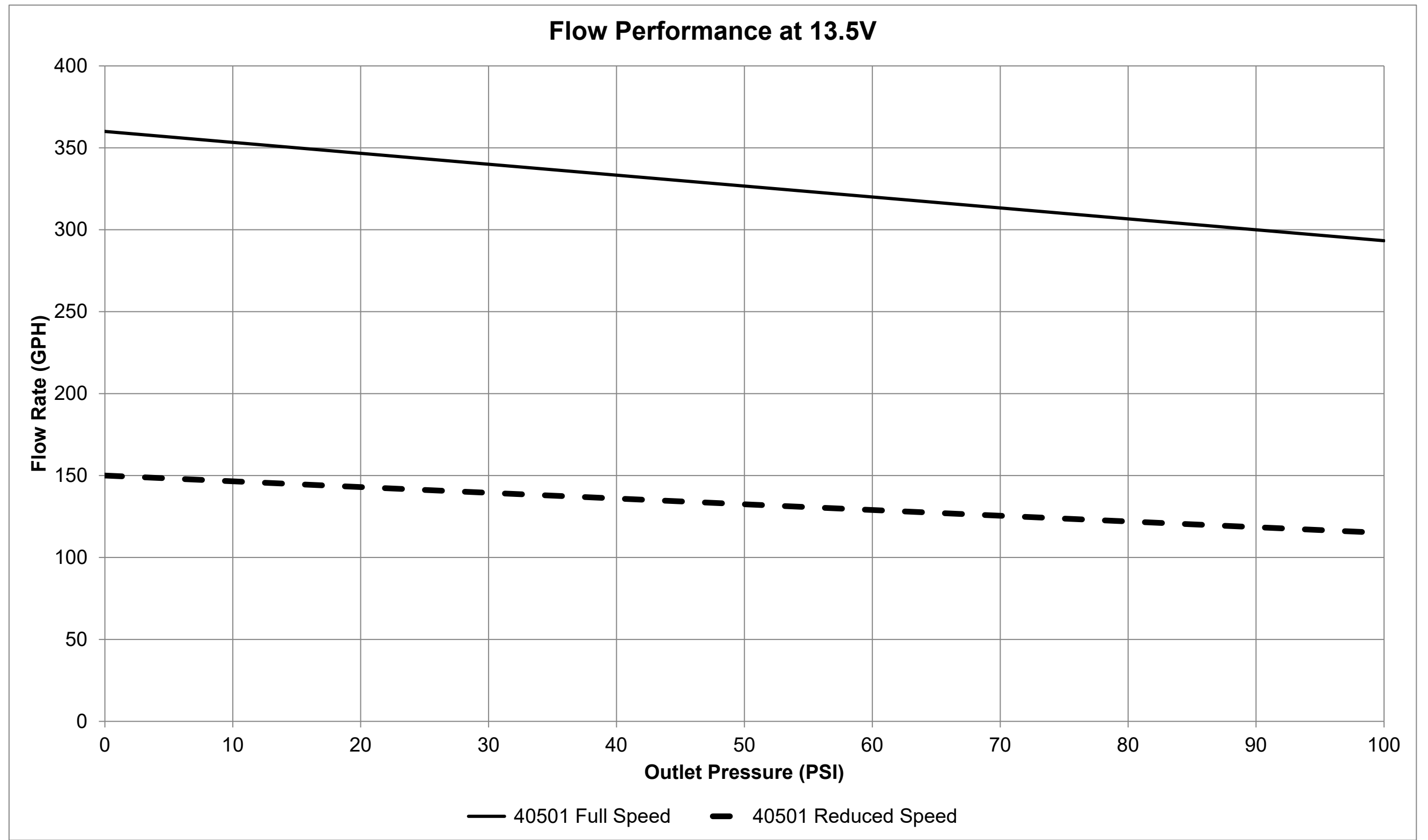

UNLESS OTHERWISE SPECIFIED: INTERPRET DWG PER ANSI Y14.5 DIMENSIONS ARE IN INCHES TOLERANCES: FRACTIONAL: ±1/64" ANGULAR: ±1/2° DECIMALS: .X±.1 .XX±.03 .XXX±.010 SURFACE FINISH: 128 ✓ OR BETTER BREAK ALL SHARP EDGES .010 MAX. REMOVE ALL BURRS		FUELAB Digital Fuel Delivery Collinsville, Illinois		
TITLE: <h2 style="margin: 0;">DC BRUSHLESS FUEL PUMP, 405xx SERIES</h2>				
SIZE <h1 style="margin: 0;">C</h1>	DWG. NO. <h1 style="margin: 0;">110021000</h1>	REV <h1 style="margin: 0;">A</h1>		
DO NOT SCALE DRAWING		SCALE: 1/1	WEIGHT: 3.5 LBS	SHEET: 2 OF 2